

TANK CONTAINER

ISO Size Type Group Codes: 20KL, 22KL

20'

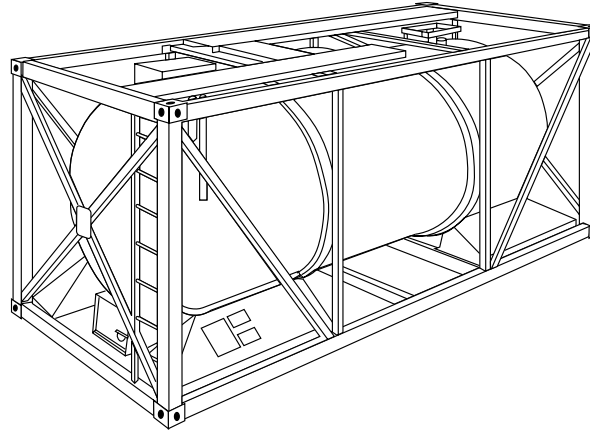

- Hapag-Lloyd can provide tank containers which are approved to the highest standards. Depending on the characteristics of the products to be carried, the requirements vary. Hapag-Lloyd offer their services on operational, technical and regulatory questions
- Separate tank fleets are available for:
 - FOODSTUFFS, e.g.:
 - Alcohols
 - Fruit juices
 - Edible oils
 - Food additives
 - CHEMICAL PRODUCTS, e.g.:
 - Flammables
 - Oxidising agents
 - Toxic substances
 - Corrosives
- Tanks must be filled to not less than 80 % of their capacity to avoid dangerous surge/swell during transport
- Tanks must not be filled to 100 % of their capacity. Sufficient ullage space shall be left – which must be determined depending on the thermal expansion of the product to be carried
- Certain dangerous products must be carried in tanks having no openings below the surface level of the liquid. Such tanks must be discharged through a syphon pipe by either pressure or pumping
- National road/rail weight limitations have to be maintained when arranging land transports
- For the cleaning of tanks and disposal of residues, dedicated rules apply